

LIUGONG
NORTH AMERICA

2025A-SC

ELECTRIC FORK TRUCK

ENGINE
Electric

RATED POWER
18.8 hp
(14 kW)

CAPACITY
5,000 LB
(2,500 kg)



XTRACARE
WARRANTY

SPECIFICATIONS

EXCLUSIVELY FOR DEALER

GENERAL

Model	CLG2020A-SC	CLG2025A-SC
Power type	1	Electric
Operator type	2	Sit-Down Rider
Base capacity	3 @rated load center	4,000 lb (2,000 kg) 5,000 lb (2,500 kg)
Load center	4	24 in (500 mm)

WEIGHTS

Service weight	5	unloaded	9,350 lb (4,250 kg)	9,680 lb (4,400 kg)
Axle load	6	loaded/unloaded, front	11,396/3,806 lb (5,180/1,730 kg)	13,222/3,740 lb (6,010/1,700 kg)
	7	loaded/unloaded, rear	2,530/5,544 lb (1,150/2,520 kg)	2,090/950 lb (950/5,940 kg)

TIRES

Tire type	8	Cushion	
Wheels	9	front/rear	2/2
Wheelbase	10	51.0 in (1295mm)	
Tire size	11	front	21 x 7 x 15 in
	12	rear	16 x 5 x 10.5 in
Tread width	13	front/rear	35/36.2 in (890/920 mm)

MAST

Max. fork height	14	with std 2-stage mast	118.1 in (3,000 mm)
Free lift	15	with std 2-stage mast	5.5 in (140 mm)
Height, upright lowered	16	with std 2-stage mast	83.9 in (2,130 mm)
Height, upright extended	17	with std 2-stage mast	161.0 in (4,090 mm)
Mast tilt, fwd, back	18	with std 2-stage mast	50;80
Carriage	19	ISO Class	II
		width	36.2 in (920 mm)
Fork spread	20	minimum/maximum	9.6/35.6 in (244/904 mm)
Fork dimensions	21	T x W x L	1.6 x 4.8 x 421 in (40 x 122 x 1,070 mm)

CHASSIS

Length to fork face	22	with std 2-stage mast	83.4 in (2,118mm)
Overall width	23	42.5 in (1,080 mm)	
Overhead guard height	24	88.0 in (2,235 mm)	
Turning radius	25	minimum outside	72.8 in (1,850 mm)
Fork overhang	26	with std 2-stage mast	16.7 in (425 mm)
Right angle stack	27	add load length and clearance	134.8 in (3,425 mm)
Ground clearance	28	minimum loaded	3.0 in (75 mm)
	29	center of wheelbase	3.9 in (100 mm)
Battery compartment	30	length/width/height	29.9 x 38.4 x 22.6 in (760 x 975 x 575 mm)

Performance

Model	CLG2020A-SC	CLG2025A-SC
Travel speed	31 loaded/unloaded	11.5/11.5 mph (18.5/18.5 km/h)
Lift speed	32 loaded/unloaded	88.6/126 fpm (.45/.64 m/s) 78.8/126 fpm (.40/.64 m/s)
Lower speed	33 loaded/unloaded	102.4/98.4 fpm (.52/.5 m/s)
Max. drawbar pull	34 5 min. rating	3,190 lb (1,450 kg)
	35 60 min. rating	697 lb (317 kg)
Max. gradeability	36 5 min. rating	20%

Systems

Controllers	37 drive/hydraulic (make, type)	AC
	38 drive output (60 min. rating)	18.8 hp (14 kW)
Motors	39 hydraulic output (15 min. rating)	24 hp (10 kW)
	40 type	Li-ion/Lead Acid
Battery	41 voltage	48/36 V
	42 max. capacity (6 hour rating)	715 Ah
	43 weight, minimum/maximum	2,395.8/3,148lb (1,089/1,431 kg)

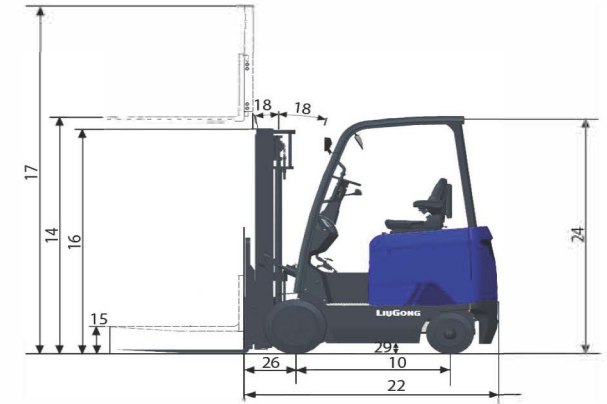
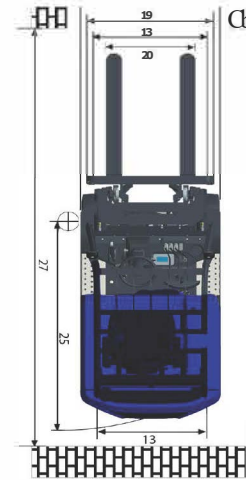

LG-NA-SS-2025A-s-c-202302-ENG-US.

Specifications and designs are subject to change without notice.
 Models shown may include optional equipment.

LiuGong Construction Machinery N.A., LLC. • T: 281-579-8882
 22220 Merchants Way - Suite 400
 Katy, TX 77449
 U.S.A.

F: 281-579-8388

www.hugor-g.com