

9051FzTS

EXCAVATOR

ENGINE	OPERATING WEIGHT	GROSS POWER	BUCKET CAPACITY	MAX. DIGGING DEPTH
Yanmar 4TNV86CT-PLY	11,420 lb (5,180 kg)	48 hp (35.5 kW)	0.18 yd ³ (0.14 m ³)	11ft 5in (3,480 mm)



SPECIFICATIONS

ENGINE

High pressure common rail, electronically controlled direct injection fuel system with 3 power modes, auto-idle and auto-shutdown features. Emissions treatment includes cooled EGR, DOC and DPF.

Emissions rating	EPA Tier 4 Final/EU Stage V
Make	Yanmar
Model	4TNV86CT-PLY
Aspiration	Turbocharged
Charged air cooling	None
Cooling fan drive	Mechanical, direct
Displacement	128 in ³ (2.09 L)
Gross power	48 hp (35.5 kW) @ 2,400 rpm
Net power	46 hp (33.5 kW) @ 2,200 rpm
Peak torque	130 lbf-ft (176.6 N-m) @ 1,560 rpm
Cylinders	4-cylinder, in-line, water-cooled
Bore x Stroke	3.4 in x 3.5 in (86 mm x 90 mm)

HYDRAULIC SYSTEM

Main pump, type	Variable-displacement piston
Main pump, maximum flow	40 gpm (149.6 L/min)
Implement pressure	3,974 psi (27.4 MPa)
Auxiliary 1, one-way pressure	2,900 psi (20 MPa)
Auxiliary 1, two-way pressure	2,900 psi (20 MPa)
Auxiliary 1, maximum flow	20 gpm (75 L/min)
Auxiliary 2, two-way pressure	2,900 psi (20 MPa)
Auxiliary 2, maximum flow	10 gpm (37 L/min)
Slew circuit pressure	2,990 psi (20.6 MPa)
Travel circuit pressure	3,770 psi (26 MPa)
Pilot pump, type	Gear pump
Pilot circuit pressure	508-566 psi (3.5-3.9 MPa)
Pilot pump, maximum flow	4.0 gpm (15 L/min)

OPERATING WEIGHT

Operating weight, typical	11,420 lb (5,180 kg)
Operating weight, maximum	12,676 lb (5,750 kg)

SERVICE CAPACITIES

Fuel tank	18 gal (70 L)
Engine oil	1.7 gal (6.3 L)
Final drive, each	0.3 gal (1.3 L)
Swing drive	0.4 gal (1.5 L)
Cooling system	3.7 gal (14 L)
Hydraulic reservoir, tank	14 gal (54 L)
Hydraulic reservoir, system	16 gal (61 L)
DEF tank	None

UNDERCARRIAGE

Traction type, typical	Rubber belt tracks, 16 in (400 mm)
Link pitch	5.31 in (135 mm)
Track width, standard	16 in (400 mm), typical
Bottom rollers, each side	4
Top rollers, each side	1

SWING SYSTEM

Planetary gear reduction driven by high torque axial piston motor, with oil disk brake. Swing parking brake resets within five seconds after swing controls return to neutral.	
Swing speed	9.6 rpm
Swing torque	9,219 lbf-ft (12,500 N-m)

DRIVE & BRAKES

2-speed axial piston motors with oil disk brakes. Steering controlled by two detachable hand levers with pedals.

Max. travel speed	High: 2.6 mph (4.2 km/h) Low: 1.5 mph (2.4 km/h)
Gradeability	30° 58%
Max. drawbar pull	13,489 lbf (60 kN)

ELECTRIC SYSTEM

System voltage	12 V
Battery	1 x 12 V
Alternator	12 V-80 A
Starter motor	3.1 hp (2.3 kW) 12 V

SOUND PERFORMANCE

Interior sound level (ISO 6396)	74 dB(A)
Exterior sound level (ISO 6395)	96 dB(A)

SPECIFICATIONS

A: Load radius
 B: Load point height
 C: Lifting capacity
 Cf: Rating over front
 Cs: Rating over side



Conditions:
 Boom length: 8 ft 10 in (2,700 mm)
 Arm length: 4 ft 9 in (1,450 mm)
 Counterweight: 639 lb (290 kg)
 Shoes: 16 in (400 mm), rubber belt
 Bucket: 0.18 yd³ (0.14 m³)

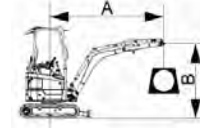

1. *Indicates the load is limited by hydraulic capacity rather than the tipping capacity.
 2. The below loads are in compliance with the ISO 10567 lift capacity rating standard and do not exceed 87% of the hydraulic lifting capacity or 75% of the tipping load.
 3. Rating at bucket lift point.

9051FzTS

Blade down

A Reach: ft (m)

B: Height ft (m)	Weight	6.6 ft (2 m)		10 ft (3 m)		13 ft (4 m)		MAX REACH		Distance
		Cf	Cs	Cf	Cs	Cf	Cs	Cf	Cs	
10 ft 3 m	lb kg					3,093 1,406	2,037 926	3,159 1,436	1,927 876	13 ft 8 in 4.15 m
6.6 ft 2 m	lb kg			3,577 1,626	2,983 1,356	3,247 1,476	2,015 916	3,181 1,446	1,597 726	15 ft 7 in 4.75 m
3.3 ft 1 m	lb kg			5,183 2,356	2,736 1,256	3,775 1,716	1,494 886	3,049 1,386	1,498 676	16 ft 5 in 5.0 m
Ground Level	lb kg			6,459 2,936	2,609 1,186	4,303 1,956	1,861 846	3,379 1,536	1,465 666	16 ft 5 in 5.0 m
-3.3 ft -1 m	lb kg	5,051 2,296	4,545 2,066	6,591 2,996	2,565 1,166	4,457 2,026	1,839 836	3,511 1,596	1,531 696	15 ft 7 in 4.75 m

9051FzTS

Blade up

A Reach: ft (m)

B: Height ft (m)	Weight	6.6 ft (2 m)		10 ft (3 m)		13 ft (4 m)		MAX REACH		Distance
		Cf	Cs	Cf	Cs	Cf	Cs	Cf	Cs	
10 ft 3 m	lb kg					2,785 1,266	2,037 926	2,653 1,206	1,927 876	13 ft 8 in 4.15 m
6.6 ft 2 m	lb kg			3,577 1,626	2,983 1,356	2,763 1,256	2,015 916	2,191 996	1,597 726	15 ft 7 in 4.75 m
3.3 ft 1 m	lb kg			3,973 1,806	2,763 1,256	2,697 1,226	1,949 886	2,015 916	1,487 676	16 ft 5 in 5.0 m
Ground Level	lb kg			3,797 1,726	2,609 1,186	2,609 1,186	1,861 846	1,993 906	1,465 666	16 ft 5 in 5.0 m
-3.3 ft -1 m	lb kg	5,051 2,296	4,545 2,066	3,731 1,696	2,565 1,166	2,565 1,166	1,839 836	2,103 956	1,531 696	15 ft 7 in 4.75 m

SPECIFICATIONS

DEALER INFORMATION HERE

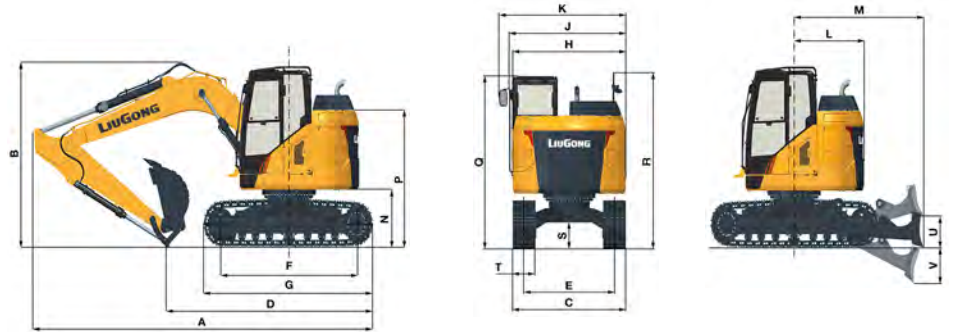
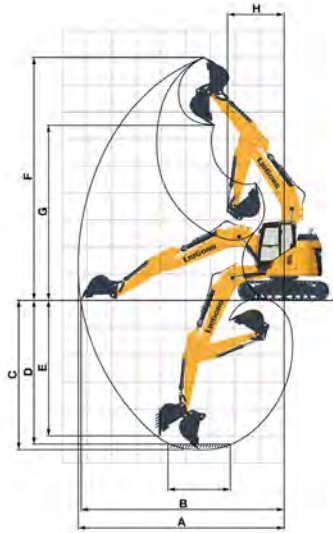

WORKING RANGES

Description	Short Arm
Boom	8 ft 10 in (2,700 mm)
Arm options	4 ft 9 in (1,450 mm)
A Max. digging reach	19 ft 4 in (5,905 mm)
B Max. digging reach at ground level	18 ft 11 in (5,765 mm)
C Max. digging depth	11 ft 5 in (3,480 mm)
D Max. digging depth 8 ft (2.4 m) level floor	8 ft 2 in (2,484 mm)
E Max. vertical wall digging depth	8 ft 3 in (2,510 mm)
F Max. digging height	17 ft 10 in (5,425 mm)
G Max. dumping height	12 ft 9 in (3,880 mm)
H Min. swing radius	8 ft 7 in (2,624 mm)
Arm digging force (ISO)	5,620 lbf (25 kN)
Bucket digging force (ISO)	8,318 lbf (37 kN)
Bucket capacity*	0.18 yd ³ (0.14 m ³)
Bucket tip radius*	33 in (850 mm)
Bucket width*	24 in (600 mm)

* Factory standard

DIMENSIONS

Description	Short Arm
Boom	8 ft 10 in (2,700 mm)
Arm options	4 ft 9 in (1,450 mm)
A Shipping length	18 ft 6 in (5,650 mm)
B Shipping height top of boom	8 ft 5 in (2,570 mm)
C Undercarriage width, standard	6 ft 5 in (1,960 mm)
D Shipping length on ground	15 ft 5 in (4,690 mm)
E Track gauge, standard	5 ft 1 in (1,560 mm)
F Length to center of rollers	6 ft 6 in (1,990 mm)
G Track length	8 ft 3 in (2,522 mm)
H Overall width of upper structure	6 ft 3 in (1,904 mm)
J Overall width including handrail	6 ft 6 in (1,979 mm)
K Overall width including cab rearview mirror	8 ft 3 in (2,504 mm)
L Tail swing radius	3 ft 2 in (965 mm)
M Distance of swing center to blade	6 ft 9 in (2,060 mm)
N Counterweight ground clearance	2 ft 2 in (651 mm)
P Overall height of counterweight	5 ft 4 in (1,634 mm)
Q Overall height of cab	8 ft 8 in (2,634 mm)
R Overall height of platform handrail	7 ft 0 in (2,134 mm)
S Minimum ground clearance	1 ft 0 in (297 mm)
T Track shoe width	16 in (400 mm) Rubber Belt Tracks 16 in (400 mm) Steel Shoes 24 in (600 mm) Steel Shoes 24 in (600 mm) Rubber Block Shoes
U Blade, maximum height	1 ft 11 in (582 mm)
V Blade, maximum depth	1 ft 7 in (489 mm)
Blade width with 20 in (500 mm) shoes	8 ft 2 in (2,490 mm)
Blade width with 24 in (600 mm) shoes	8 ft 6 in (2,590 mm)

LGNA-SS-9051FZTS-202302-ENG-US

Specifications and designs are subject to change without notice.
Machines shown may include optional equipment.

LiuGong Construction Machinery N.A., LLC.
22220 Merchants Way - Suite 100
Katy, TX 77449
USA

T: 281-579-8882
www.liugongna.com

F: 281-579-8388