950E

EXCAVATOR

Engine

Cummins QSG12 Tier 4 Final

Gross Power

400 hp (298 kW)

Operating Weight

108,467 lb (49,200 kg)

Bucket Capacity

2.88 yd³ (2.2 m³)



TOUGH WORLD. TOUGH EQUIPMENT.

UNBEATABLE RETURN ON YOUR INVESTMENT

LiuGong's **customer-driven** design and **quality-focused** engineering creates lasting value that will deliver to your bottom line.

DEPENDABLE POWER

Unmatched performance driven by the Cummins QSG12 Tier 4 Final Engine.

IPC (INTELLIGENT POWER CONTROL)

IPC ensures the mechanical, electrical, and hydraulic systems work in perfect harmony for efficient precise control. Maximizing torque outlet with more power and breakout force.

AUTO-IDLE SPEED FUNCTION

Hydraulic signals detect activity, decreasing, and increasing engine speed as required. Power is supplied only as needed, achieving optimum fuel efficiency.

VERSATILITY

Options for auxiliary hydraulic piping include bi-directional variable high flow lines, an additional line for rotating attachments and a single acting line. The quick coupler further ensures you get the most out of your machine by easily switching between a wide range of attachments to suit your needs.



BOOM AND ARM

Boom and arm structures are designed for long-term durability and resistance to bending and torsional stress. Large cross-sectional areas incorporate one-piece steel castings to provide improved strength and standard rock guard plates and vertical guards further protect the arm in rocky conditions.

UNDERCARRIAGE

Outstanding stability and durability come from an X-type reinforced frame and the long track beam and crawler system.

REAR VIEW CAMERA

Like an extra eye outside the machine, the standard rear view camera sends images to the in-cab color LCD monitor, creating a safer working environment as you concentrate on the work at hand.

PARTS

Using genuine LiuGong parts is key to keeping your costs low and your machine in top working order. Our extensive support network is always there when you need it, to maximize your business profitability.

AFTER SALES SERVICE

As a customer of LiuGong you can feel confident that our dealers and regional offices will be there to support you with training, service and maintenance needed throughout the life of your machine.



DESIGNED TO GET MORE DONE

The 950E is designed to **get more done** in less time. Featuring a stronger boom, arm and bucket breakout force, greater hydraulic flow, higher swing speeds and improved cycle times, this excavator will power **through any task** in any terrain.

POWERFUL PERFORMANCE

The Cummins QSG12 engine produces gross power of 298 kW (400 hp) and torque of 2,034 N-m (1,500 lb-ft). LiuGong has harnessed this power for six working modes to the job at hand and even the least experienced of operators will find they can work faster and complete more in less time.

OPTIMIZED HYDRAULICS

Where intelligence meets brute force. Load-sensing hydraulics direct the engine's power to ensure hydraulic pump flow continually adjusts for smooth, quick, and efficient operation.

OPERATOR FRIENDLY ENVIRONMENT

Ergonomically designed controls, clear and informative displays, increased visibility, and exceptional comfort increases operator efficiency and safety.



EFFICIENCY, PRECISION & VERSATILITY

LiuGong E-Series excavators deliver the **perfect balance** of performance, precision, and quality. The 950E model is powered by the latest generation, low emission Cummins QSG12 engine, with enhanced power output, **improved breakout force** and faster cycle times.

A POWERFUL ENGINE

Cummins QSG12 engine meets strict US EPA Tier 4 Final emissions standards. Delivering the greatest possible fuel economy without compromising on power.

Cummins designed integration system:

- Combustion technology
- Cummins Aftertreatment system
- EGR (Exhaust Gas Recirculation)
- VGT (Variable Geometry Turbocharger) improves boost across all engine speeds
- Latest after treatment technology. Together increases engine performance, improves fuel economy while reducing exhaust emissions to US EPA standards.

SAFETY STANDARDS

All LiuGong E-Series excavators come with certified ROPS (Rollover Protective System) cabs meeting ISO safety standards. LiuGong offers FOPS (Falling Object Protective Structure) as an option on all E-Series excavators.

ALL AROUND VISION FEATURES

LiuGong's E-Series cabs have seven percent larger glass surface area compared to our D-Series cab. Combined with standard rear view camera gives the operator a panoramic view. Combined with optional LED work lights provides clearer line of sight on jobsites.

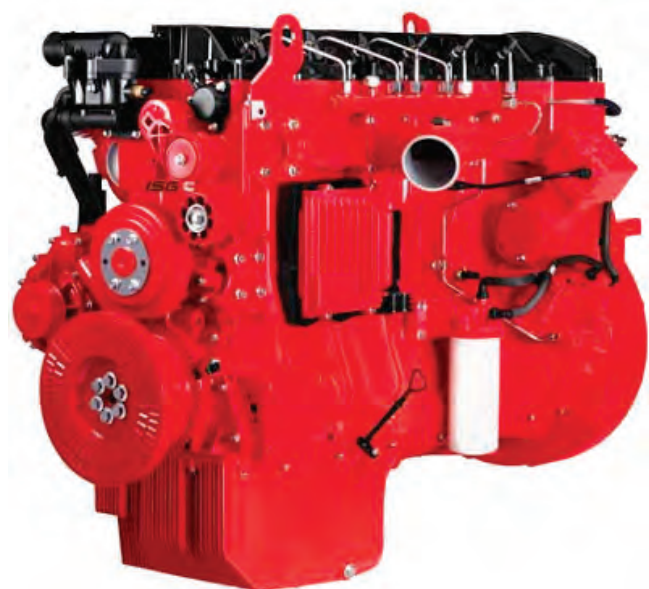

ALL AROUND COMFORT

In the 950E cab, you're working in complete **comfort** with outstanding **visibility** all around. We understand how operators like to work and have designed the cab for **maximum comfort** and ultimate productivity.

AT HOME IN THE CAB

The E-Series cab is ROPS ISO 12117-2 certified mounted on dampener silicone to absorb noise and vibration. Wide spacious cab door swings full open to lock position. Front windshield slides up into ceiling, removable lower window, large roof skylight with sun screen.

ADVANCED CLIMATE CONTROL

Pressurized cab, advanced climate control, air is circulating through cab by ten outlets to improve air circulation and front windshield defrost allow year around operator comfort in any environment.

ADJUSTABLE SEAT AND JOYSTICK CONSOLE

The adjustable seat and joystick console move independently to accommodate the operator. Increased spacing between the armrest and nine different seat adjustments allow the operator more options to all foot and hand controls to maximum comfort.



MONITORING & SERVICING MADE EASY

LiuGong's new display interface can bring to the operator's attention **more features** than ever before.



ON BOARD MONITORING

LiuGong's new on board monitoring LCD display interface with audible sound alerts the operator to low fluid levels, high level machine warnings, and when maintenance service is needed. When fuel level is low, or DEF (Diesel Exhaust Fluid) is low, a text warning will appear where date and time is located on monitor. In addition, an audible buzz will sound to alert the operator to what action is needed. If this is a low-level fault, the buzz sound can be cancelled.



TRAVEL CAMERA STANDARD

When traveling in forward or reverse the display changes to a camera monitor. A camera mounted on rear of counterweight gives the operator an excellent view of what is behind the counterweight. This function can be accessed anytime by pressing the F3 switch.

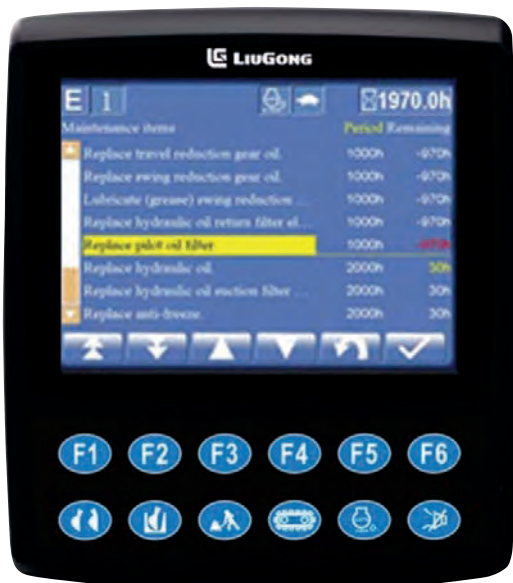

MAINTENANCE MENU INTERFACE OPERATION

With easy access to the maintenance menu through our monitor, the operator can confirm which items should be checked 8 hours, 50 hours, and 100 hours up to 2000 hours.

Here you can easily track the various maintenance parameters of your machine to confirm your excavator is receiving the proper care which will extend the life of your machine.

ALWAYS STRONG ALWAYS RELIABLE

The use of thick, high-tensile steel components, internal baffling, and stress-relieved plates, make the structures on LiuGong E-Series excavators **tough and durable**.

We guarantee the **quality and reliability** of our machines throughout the manufacturing process by conducting stringent tests and ultrasound inspections that detect defects well before they make it into production.



BOOM & ARM

The boom and arm structures are designed with large cross-sectional supports and incorporate one-piece steel castings. This solid engineering guarantees long-term durability and high resistance to bending and torsional stress. Standard rock-guard plates and vertical guards protect the arm in rocky digging conditions and tough environments.

UPPER STRUCTURE

The upper structure is strongly reinforced by the use of an H-beam in the high cross section of the main structure providing even weight distribution and increasing stability.

The platform's collision protection system has been welded into place to improve its strength, rigidity and overall service life.



UNDERCARRIAGE

The high-strength undercarriage of the 950E incorporates a welded X-frame construction for long life durability and is designed to perform in the most challenging applications.

A long track beam and crawler system provides greater stability when using attachments for digging and truck loading. The result is outstanding strength and durability.

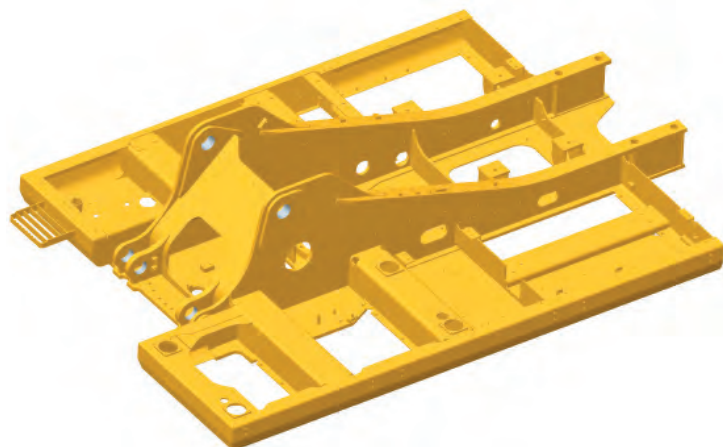

PART OF YOUR PERFORMANCE

LiuGong engineering sets high standards and all parts are rigorously tested to ensure they can meet the rigid quality specifications required for long lasting performance. No matter where you are in **North America**, we can ensure fast and efficient parts support to keep you going.



We know that confidence in your machine and those who support it is essential. At LiuGong North America we make sure we can always get what you need without delay, via our global parts depot, and the support of our local dealer network.

READY FOR ANY JOB

LiuGong provides a range of purpose designed attachments, hitches and tools for your 950E to give you increased versatility for any jobsite. In-cab dial-in hydraulic flow settings through the display screen optimizes the attachment performance.



BUCKETS



QUICK COUPLER



HAMMER

SPECIFICATIONS

ENGINE	
Description	
Cummins Tier 4 Final 11.8 liter 6-cylinder Variable-Geometry Turbocharger (VGT) Air Cleaner: Cummins direct flow air filter.	
Emissions rating	EPA Tier 4 Final / Stage IV
Make	Cummins
Model	QSG12
Aspiration	Variable-Geometry Turbocharger
Charged air cooling	Aftercooler
Cooling fan drive	Viscous clutch
Displacement	11.8 L (720 in ³)
Gross power	298 kW (400 hp) @ 2,100 rpm
Net power	282 kW (378 hp) @ 2,100 rpm
Peak torque	2,034 N-m (1,500 lb-ft) @ 1,400 rpm
Number of cylinders	6
Bore x Stroke	132 x 144 mm (5.2 x 5.7 in)
HYDRAULIC SYSTEM	
Main pump	
Type	Two variable displacement piston pumps
Maximum flow	2 x 380 L/min (100 gal/min)
Pilot pump	
Type	Gear pump
Maximum flow	28.5 L/min (7.5 gal/min)
Relief valve setting	
Implement	32.3/35.3 MPa (4,685/5,120 psi)
Travel circuit	32.3 MPa (4,685 psi)
Slew circuit	28 MPa (4,061 psi)
Pilot circuit	3.9 MPa (566 psi)
Hydraulic cylinders	
Boom Cylinder Bore x Stroke	165 mm x 1,560 mm (6.5 in x 5 ft 1 in)
Arm Cylinder Bore x Stroke	190 mm x 1,980 mm (7.5 in x 6 ft 6 in)
Bucket Cylinder Bore x Stroke	170 mm x 1,260 mm (6.7 in x 4 ft 2 in)
SERVICE CAPACITIES	
Fuel tank	650 L (172 gal)
Engine oil	34 L (9.0 gal)
Final drive (each)	15 L (4.0 gal)
Swing drive	2 x 5.3 L (2 x 1.4 gal)
Cooling system	33 L (8.7 gal)
Hydraulic reservoir	290 L (77 gal)
Hydraulic system total	520 L (137 gal)
DEF tank	56.8 L (15.0 gal)

UNDERCARRIAGE	
Track shoe each side	51
Link pitch	216 mm (8.5 in)
Shoe width, triple grouser	800 mm (31.5 in)
Bottom rollers each side	9
Top rollers each side	2
SWING SYSTEM	
Description	
Planetary gear reduction driven by high torque axial piston motor, with oil disk brake. Swing parking brake resets within five seconds after swing pilot controls return to neutral.	
Swing speed	8.5 rpm
Swing torque	165,300 N-m (121,919 lb-ft)
DRIVE AND BRAKES	
Description	
2-speed axial piston motors with oil disk brakes. Steering controlled by two detachable hand levers with pedals.	
Max. travel speed	High: 5.5 km/h (3.4 mph) Low: 3.3 km/h (2.1 mph)
Gradeability	35° / 70%
Max. drawbar pull	320 kN (71,939 lbf)
ELECTRIC SYSTEM	
System voltage	24V
Batteries	2 x 12V
Alternator	24V - 70A
Starter motor	24V - 7.5 kW (24V - 10.1 hp)
SOUND PERFORMANCE	
Interior sound level (ISO 6396)	76 dB(A)
Exterior sound level (ISO 6395)	106 dB(A)

SPECIFICATIONS

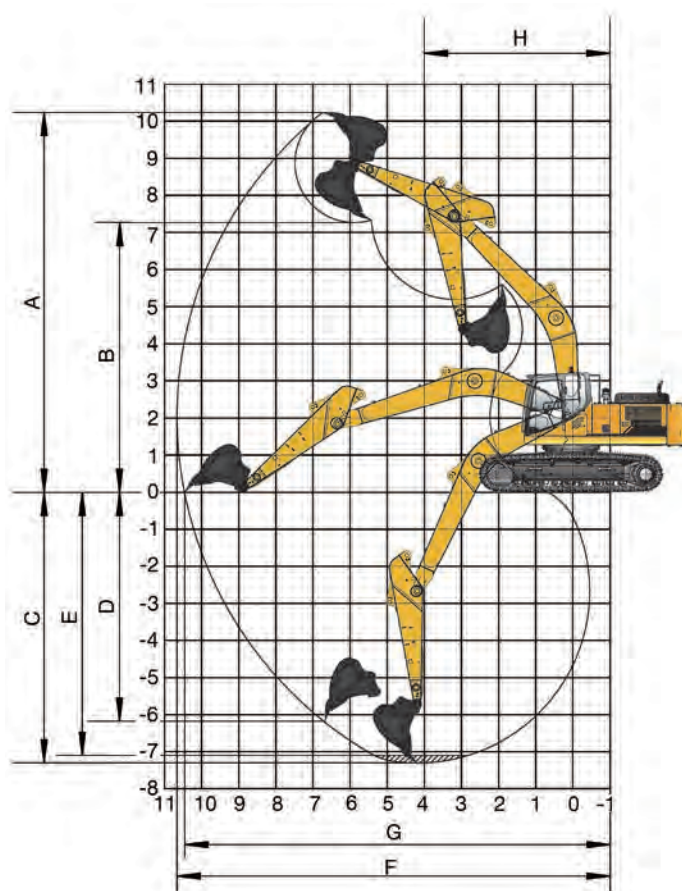

WORKING RANGES

Description		Standard Arm	Short Arm
Boom		7.06 m (23 ft 2 in)	
Arm options		3.38 m (11 ft 1 in)	2.9 m (9 ft 6 in)
A	Max. digging height	10,785 mm (35 ft 5 in)	10,618 mm (34 ft 10 in)
B	Max. dumping height	7,520 mm (24 ft 8 in)	7,578 mm (24 ft 10 in)
C	Max. digging depth	7,860 mm (25 ft 9 in)	7,380 mm (24 ft 3 in)
D	Max. vertical wall digging depth	6,435 mm (21 ft 1 in)	6,011 mm (19 ft 9 in)
E	Max. digging depth 2.4 m (8 ft) level bottom	7,715 mm (25 ft 4 in)	7,218 mm (23 ft 8 in)
F	Max. digging reach	12,020 mm (39 ft 5 in)	11,585 mm (38 ft 0 in)
G	Max. digging reach at ground level	11,810 mm (38 ft 9 in)	11,368 mm (37 ft 4 in)
H	Min. swing radius	5,015 mm (16 ft 5 in)	5,052 mm (16 ft 7 in)
Bucket digging force (ISO)	Normal	209 kN (46,985 lbf)	240 kN (53,954 lbf)
	Power boost	225 kN (50,582 lbf)	263 kN (59,125 lbf)
Arm digging force (ISO)	Normal	268 kN (60,249 lbf)	263 kN (59,125 lbf)
	Power boost	288 kN (64,745 lbf)	287 kN (64,520 lbf)
Bucket capacity		2.2 m ³ (2.88 yd ³)	2.2 m ³ (2.88 yd ³)
Bucket tip radius		1,837 mm (6 ft 0 in)	1,837 mm (6 ft 0 in)

SPECIFICATIONS

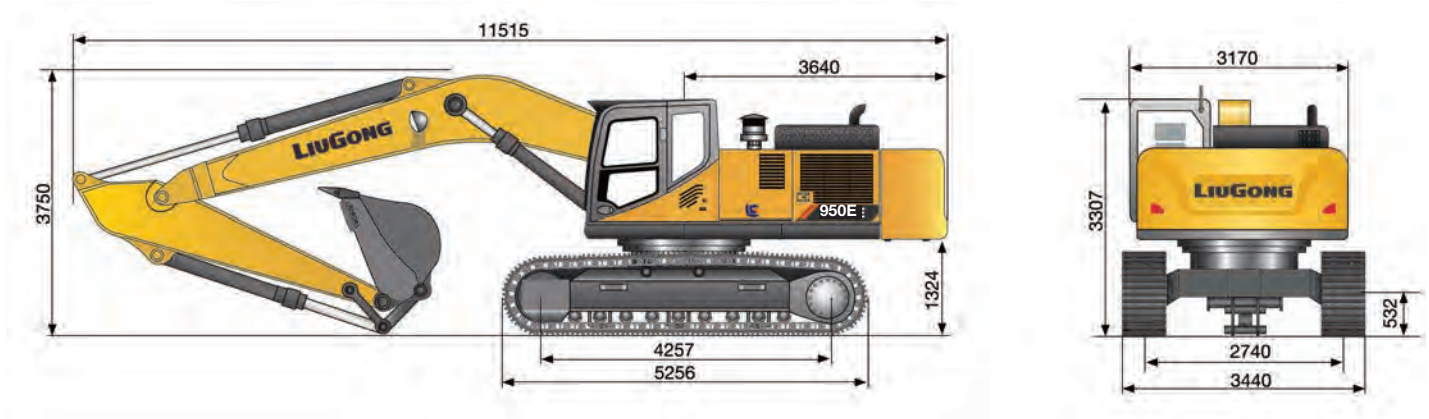

DIMENSIONS		
	Standard Arm	Short Arm
Boom	7.06 m (23 ft 2 in)	
Arm options	3.38 m (11 ft 1 in)	2.9 m (9 ft 6 in)
A Shipping length	12,062 mm (39 ft 7 in)	12,030 mm (39 ft 6 in)
B Shipping height top of boom	3,690 mm (12 ft 1 in)	3,810 mm (12 ft 6 in)
C Track gauge	2,740 mm (9 ft 0 in)	2,740 mm (9 ft 0 in)
D Undercarriage width	3,540 mm (11 ft 7 in)	3,540 mm (11 ft 7 in)
E Length to center of rollers	4,257 mm (14 ft 0 in)	4,257 mm (14 ft 0 in)
F Track length	5,256 mm (17 ft 3 in)	5,256 mm (17 ft 3 in)
G Overall width of upper structure	3,170 mm (10 ft 5 in)	3,170 mm (10 ft 5 in)
H Tail swing radius	3,640 mm (11 ft 11 in)	3,640 mm (11 ft 11 in)
I Counterweight ground clearance	1,324 mm (4 ft 4 in)	1,324 mm (4 ft 4 in)
J Overall height of cab	3,307 mm (10 ft 10 in)	3,307 mm (10 ft 10 in)
K Min. ground clearance	532 mm (1 ft 9 in)	532 mm (1 ft 9 in)
Track shoe width	800 mm (31.5 in)	800 mm (31.5 in)

SPECIFICATIONS

950E WITH 800 MM (31.5 IN) SHOES, 3.38 M (11 FT 1 IN) ARM

- A: Reach from swing center
- B: Bucket hook height
- C: Lifting capacity
- Cf: Rating over front
- Cs: Rating over side

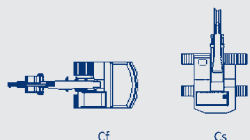

Conditions:
 Boom length: 23 ft 2 in (7.06 m)
 Arm length: 11 ft 1 in (3.38 m)
 Counterweight: 19,842 lb (9,000 kg)
 Shoes: 800 mm (31.5 in) triple grouser
 Bucket: SAE 2.2 m³ (2.88 yd³) 2,092 kg (4,612 lb)

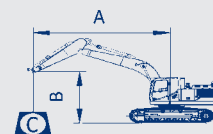

A Reach: m (ft)

B: Height m (ft)		3 m (10 ft)		4.5 m (15 ft)		6 m (20 ft)		7.5 m (25 ft)		9 m (30 ft)		MAX REACH		
		Cf	Cs	Cf	Cs	Cf	Cs	Cf	Cs	Cf	Cs	Front	Side	Distance
7.5 m	kg											*8,810	*8,810	8.7 m
25 ft	lb											*19,423	*19,423	28 ft 6 in
6 m	kg							*11,470	11,100	*10,610	8,400	*9,380	7,830	9.4 m
20 ft	lb							*25,287	24,471	*23,391	18,519	*20,679	17,262	30 ft 8 in
4.5 m	kg			*19,100	*19,100	*14,640	*14,640	*12,330	10,730	*10,960	8,240	*9,270	7,130	9.9 m
15 ft	lb			*42,108	*42,108	*32,276	*32,276	*27,183	23,656	*24,163	18,166	*20,437	15,719	32 ft 6 in
3 m	kg			*22,800	20,740	*16,440	13,970	*13,290	10,320	*11,430	8,030	*10,110	6,810	10.1 m
10 ft	lb			*50,265	45,724	*36,244	30,798	*29,299	22,752	*25,199	17,703	*22,289	15,013	33 ft 2 in
1.5 m	kg			*21,780	18,780	*17,730	13,350	*14,050	9,960	*11,800	7,830	10,110	6,710	10.1 m
5 ft	lb			*48,017	41,403	*39,088	29,432	*30,975	21,958	*26,014	17,262	22,289	14,793	33 ft 2 in
0 m	kg			*21,730	19,450	*18,180	13,000	*14,390	9,710	11,730	7,690	10,310	6,820	9.9 m
0 ft	lb			*47,906	42,880	*40,080	28,660	*31,724	21,407	25,860	16,953	22,730	15,035	32 ft 6 in
-1.5 m	kg	*16,000	*16,000	*22,880	19,490	*17,720	12,890	*14,130	9,610	*11,440	7,650	*10,550	7,180	9.5 m
-5 ft	lb	*35,274	*35,274	*50,442	42,968	*39,066	28,417	*31,151	21,186	*25,221	16,865	*23,259	15,829	31 ft 2 in
-3 m	kg	*25,170	*25,170	*20,560	19,720	*16,310	12,970	*13,000	9,670			*10,540	8,080	8.7 m
-10 ft	lb	*55,490	*55,490	*45,327	43,475	*35,957	28,594	*28,660	21,319			*23,237	17,813	28 ft 6 in
-4.5 m	kg	*20,430	*20,430	*16,910	*16,910	*13,590	13,250	*10,250	9,950			*9,970	9,790	7.6 m
-15 ft	lb	*45,040	*45,040	*37,280	*37,280	*29,961	29,211	*22,597	21,936			*21,980	21,583	25 ft 0 in

1. * Indicates the load is limited by hydraulic capacity rather than the tipping capacity.
2. The above loads are in compliance with the ISO 10567 hydraulic rating standard. They do not exceed 87% of the hydraulic lifting capacity of 75% tipping load.
3. Rating at bucket lift hook.

SPECIFICATIONS

MACHINE WEIGHTS AND GROUND PRESSURE

Operating weight includes boom 7.06 m (23 ft 2 in), arm 3.38 m (11 ft 1 in), bucket 2.2 m³ (2.88 yd³) counterweight 9,000 kg (19,842 lb) full fuel tank, and operator.

Shoe Width	Operating Weight	Ground Pressure	Overall Width
800 mm (31.5 in)	49,200 kg (108,467 lb)	65.3 kPa (9.5 psi)	3,540 mm (11 ft 7 in)

Boom



Arm



BOOM DIMENSIONS

Description	Standard
Boom	7.06 m (23 ft 2 in)
Length	7,350 mm (24 ft 1 in)
Height	1,850 mm (6 ft 1 in)
Width	1,057 mm (3 ft 5 in)
Weight	4,350 kg (9,590 lb)
Includes cylinder, piping and pin, excludes boom cylinder pin.	

ARM DIMENSIONS

Description	Standard	Short
Arm	3.38 m (11 ft 1 in)	2.9 m (9 ft 6 in)
Length	4,750 mm (15 ft 7 in)	4,245 mm (13 ft 11 in)
Height	1,150 mm (3 ft 9 in)	1,150 mm (3 ft 9 in)
Width	602 mm (2 ft 0 in)	602 mm (2 ft 0 in)
Weight	2,500 kg (5,512 lb)	2,310 kg (5,093 lb)
Includes cylinder, piping and pin, excludes boom cylinder pin.		

BUCKET SELECTION GUIDE

Bucket Type	Capacity	Cutting Width	Weight	Teeth Pcs	HD Boom 7.06 m (23 ft 2 in)	HD Boom 7.06 m (23 ft 2 in)
					Arm 2.9 m (9 ft 6 in) Shoes 800 mm (31.5 in)	Arm 3.38 m (11 ft 1 in) Shoes 800 mm (31.5 in)
Heavy Duty	2.2 m ³ (2.88 yd ³)	1,775 mm (70 in)	2,092 kg (4,612 lb)	5	◇	◇
	2.6 m ³ (3.4 yd ³)	1,602 mm (63 in)	2,220 kg (4,894 lb)	5	□	□
	3.2 m ³ (4.2 yd ³)	1,900 mm (75 in)	2,817 kg (6,210 lb)	5	X	X

Maximum material density

- Used with material weights up to 1,400 - 1,600 kg/m³ (2,360 - 2,697 lb yd³) wet earth and clay, Limestone, Sandstone
- ◇ Used with material weights up to 1,900 kg/m³ (3,203 lb yd³) wet earth and clay, Limestone, Sandstone
- X Not Applicable



STANDARD EQUIPMENT

ENGINE

- Cummins QSG12 certified to stringent US EPA Tier 4 Final emission standards
- Auto idle speed control
- 2 Stage air filters with pre-cleaner
- VGT (Variable Geometry Turbocharger)
- Fuel system pre-filter with water separator
- Radiator, oil cooler and intercooler
- IPC (Intelligent Power Control) system
- Engine overheating prevention system

HYDRAULIC SYSTEM

- Manual power boost
- Auto power boost
- Boom and arm regeneration circuits
- Pilot oil filter
- Load holding valve
- Pilot control shut-off lever
- Swing with anti-reverse function
- Control pattern changer valve
- Bi-directional piping to arm
- 2-joystick with multi buttons

TELEMATICS

- 36 months service from initial sale
- Positioning and engine on/off history

OPERATOR STATION

- Travel rear-view camera
- 3 halogen work lights
- Pressurized and sealed cab with all around visibility
- Front window wiper
- Removable lower window
- 6-working mode selection system: Power Mode, Economy Mode, Fine Mode, Lifting Mode, Breaker Mode and Attachment Mode
- Skylight rooftop w/ sliding sun visor
- Air conditioner, heater, defroster
- AM/FM Radio with MP3 audio jack
- Color LCD monitor with alarms, filter/fluid change, fuel rate, water temperature, work mode, fault code, working hour, seven language setting
- Glass-breaking hammer
- Fire extinguisher
- Cup holder
- Floor mat
- Storage box
- Rotation beacon
- Front glass lower guard
- Travel alarm
- Front window rain guard

UPPER STRUCTURE

- Rear view mirror (right & left side)
- 2 batteries
- One key for all locks
- Fuel gauge
- Hydraulic oil level gauge
- Storage box
- Swing parking brake
- Boom working lights
- Light integrated into storage box
- Rollover Protective System (ROPS) Cab

UNDERCARRIAGE

- 800 mm (31.5 in) triple grouser track shoes
- 3 piece track-guards (each-side)
- Towing eye on base frame
- Sealed and lubricated track chain

WORK EQUIPMENT

- 7.06 m (23 ft 2 in) boom
- 3.38 m (11 ft 1 in) arm
- 2.2 m³ (2.88 yd³) bucket heavy duty

OPTIONAL EQUIPMENT

ENGINE SYSTEM

- Electrical fuel refilling pump

HYDRAULIC SYSTEM

- Security valves (2 on boom and 1 on arm)
Auxiliary Hydraulic options
- PTO rotating piping
- Hi pressure quick coupler piping

OPERATOR STATION

- Power outlet 24V to 12V converter
- 3 LED working lights
- Air suspension seat
- Falling Object Protective Structure (FOPS)

UNDERCARRIAGE

- 600, 700, 900 mm track-shoes with triple grousers

FEATURES TO ENHANCE YOUR PRODUCTIVITY

- LED lights
- Attachment piping
- Auto lube system

ARM

- Arm 2.9 m (9 ft 6 in)



LiuGong Construction Machinery N.A, LLC.

22220 Merchants Way - Suite 100
Katy, TX 77449
USA

T: 281-579-8882 F: 281-579-8388
www.liugongna.com

Like and follow us:



LG-PB-950E-012020-ENG-US

The LiuGong series of logos herein, including but not limited to word marks, device marks, letter of alphabet marks and combination marks, as the registered trademarks of Guangxi LiuGong Group Co., Ltd. are used by Guangxi LiuGong Machinery Co., Ltd. with legal permission, and shall not be used without permission. Specifications and designs are subject to change without notice. Illustrations and pictures may include optional equipment and may not include all standard equipment. Equipment and options varies by regional availability.