

LIUGONG
NORTH AMERICA

835Hv

WHEEL LOADER

ENGINE
Cummins
B4.5

OPERATING WEIGHT
28,053 lb
(12,725 kg)

GROSS POWER
154 hp
(115 kW)

BUCKET SIZE
2.5 yd³
(1.9 m³)



SPECIFICATIONS

ENGINE

Emissions rating	EPA Tier 4 Final / EU Stage V
Make	Cummins
Model	B4.5
Gross power	154 hp (115 kW) @ 2,200 rpm
Net power	142 hp (106 kW) @ 2,200 rpm
Peak torque	525 lbf-ft (712 N·m) @ 1,200 rpm
Cylinders	4
Displacement	1.18 gal (4.5 L)
Aspiration	Turbocharged & Air-to-air intercooled

TRANSMISSION

Transmission type	Countershaft, power shift
Torque converter	Single stage, three elements
Max. travel speed, fwd	23.6 mph (38 km/h)
Max. travel speed, rev	15.9 mph (25.6 km/h)
Number of speeds, fwd	4
Number of speeds, rev	3

AXLES

Differential front type	Limited slip
Differential rear type	Limited slip
Axle oscillation	±12°

STEERING

Steering configuration	Articulated
Steering pressure	2,611 psi (18 Mpa)

BRAKES

Service brake type	Wet disc brake
Service brake actuation	Fully hydraulic
Parking brake type	Drum
Parking brake actuation	Electro-hydraulic release

HYDRAULIC SYSTEM

Main pump type	Piston
System pressure	3,771 psi (26 MPa)
Raise	4.8 s
Dump time	1.5 s
Float down time	3.1 s
Total cycle time	9.4 s

BUCKET PERFORMANCE

Bucket capacity	2.0-5.2 yd ³ (1.5-4.0 m ³)
-----------------	---

TIRES

Tire size	17.5R25 L3
-----------	------------

OPERATING WEIGHT

Operating weight	28,053 lb (12,725 kg)
------------------	-----------------------

SERVICE CAPACITY

Fuel tank	57.3 gal (217 L)
Engine oil	3 gal (11.6 L)
Cooling system	7.4 gal (28 L)
Hydraulic system	33 gal (125 L)
Transmission	10.5 gal (40 L)
Axles, each	9 gal (34 L)
DEF tank	5 gal (19 L)

SPECIFICATIONS

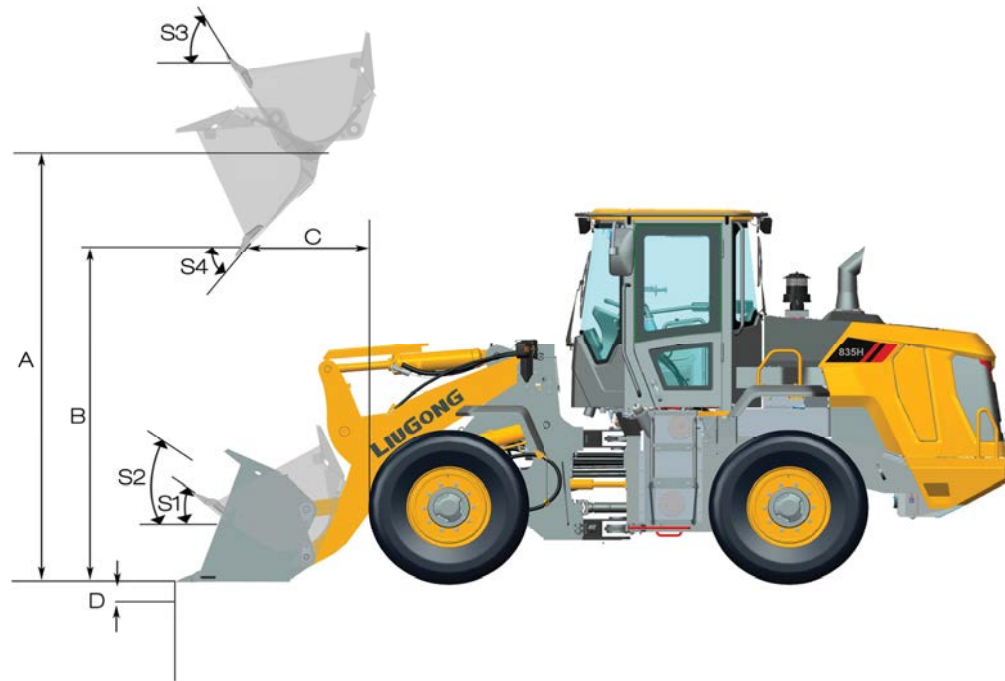

LOADER ARM PERFORMANCE WITH ATTACHMENT

Description

Tipping load - straight	19,522 lb (8,855 kg)
Tipping load - full turn	16,480 lb (7,475 kg)
Bucket breakout force	20,233 lbf (90 kN)
A Maximum hinge pin height	12 ft 3 in (3,738 mm)
B Dump clearance at full height discharge	8 ft 9 in (2,680 mm)
C Dump reach at full height discharge	3 ft 10 in (1,168 mm)
D Max. digging depth, bucket level	2.3 in (60 mm)
S ₁ Bucket rollback at ground level	42°
S ₂ Bucket rollback at carry	49°
S ₃ Bucket rollback at max. height	56°
S ₄ Max. dump angle at full height	45°

SPECIFICATIONS

EXCLUSIVELY FOR DEALER

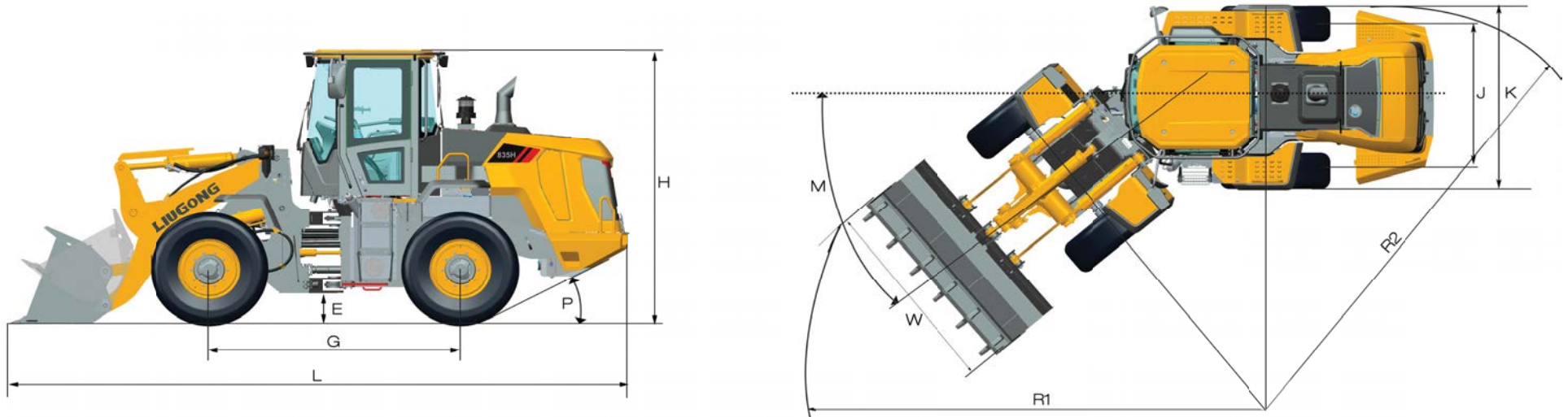

DIMENSIONS

Description

E	Ground clearance	1 ft 4 in (400 mm)
G	Wheelbase	9 ft 7 in (2,940 mm)
H	Cab height	11 ft 1 in (3,370 mm)
J	Wheel tread	6 ft 3 in (1,910 mm)
K	Width over tires	7 ft 9 in (2,355 mm)
L	Length with bucket down	24 ft 1 in (7,347 mm)
M	Turn angle, either side	40°
P	Rear angle of departure	31°
R ₁	Turning radius, bucket carry	19 ft 1 in (5,807 mm)
R ₂	Turning radius, outside of tire	17 ft 5 in (5,313 mm)
W	Width over bucket	8 ft 1 in (2,460 mm)

LGNA-SS-835HV-202207-ENG-US

Specifications and designs are subject to change without notice.
Machines shown may include optional equipment.

Liugong Construction Machinery N.A., LLC.
22220 Merchants Way - Suite 100
Katy, TX 77449
USA

T: 281-579-8882
www.liugongna.com

F: 281-579-8388